

SERVICE AND WIRING SHEET

03-May-2006 00:06:12

2313882 REL



⚠ WARNING

Electrical Shock Hazard
Disconnect power before servicing.
Replace all parts and panels before operating.
Failure to do so can result in death or electrical shock.

- Normal operating conditions are viewed when the air temperature is between 55 and 100°F. Best results when air is between 70 and 90°F

NOTE: Watt and pressure readings will vary and are influenced by the existing condition of the appliance, such as iced-up evaporator, condition of condenser, defrost cycle, pull-down time and customer use.

PERFORMANCE DATA			
TEMPERATURE	SYSTEM PRESSURE AT THE END OF FREEZER CYCLE		CYCLE TIME IN MINUTES
	SUCTION	HEAD	
AMBIENT 70° WATER 60°	1-4	65-80	18-22
AMBIENT 90° WATER 60°	2-5	85-100	21-27
AMBIENT 100° WATER 60°	2-6	85-105	24-28
AMBIENT 70° WATER 80°	1-4	65-80	20-25
AMBIENT 90° WATER 80°	2-5	85-100	23-29
AMBIENT 100° WATER 80°	2-6	85-105	24-28

SERVICE INFORMATION (2313880 REL)

- REFRIGERANT CHARGE MUST BE APPLIED TO THE HIGH SIDE ONLY.
- THIS UNIT OPERATES AT 120 volts AC EXCEPT FOR CUTTER GRID, ELECTRONIC CONTROLS AND (OPTIONAL) LIGHT WHICH OPERATES AT 8.7 VOLTS.
- THE TRANSFORMER, CUTTER GRID AND ELECTRONIC CONTROL REMAIN ENERGIZED IN ON & CLEAN MODE.

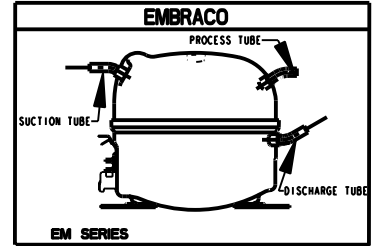
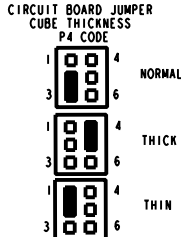

SERVICEABLE ELECTRICAL PARTS MATRIX

SERVICEABLE PARTS	15" ICEMAKER		WATTAGE		RESISTANCE	
	120V		@120V			
COMPRESSOR	2208370		244		*	
RUN WINDINGS	*		*		1-5	
START WINDINGS	*		*		3-11	
RELAY	2217224		*			
OVERLOAD	2217223		*			
CIRCULATING PUMP	2208482		26-30		19.6	
WATER VALVE	2313644		15 NOM.		250-300	
SOLENOID COIL (HGV)	759112		7-9		385	
THERMISTOR BIN	2313633		*		10k@25°C	
THERMISTOR-ICE CONTROL	2313635		*		10k@25°C	
PC BOARD	2304016		23			
TRANSFORMER	2185657		40			
CONDENSER FAN MOTOR & MTG PLATE ASSY	2188537		5.1-7.1		185	

ICE BIN THERMISTOR

BIN	CUT-IN		CUT-OUT	
	TEMPERATURE	RESISTANCE	TEMPERATURE	RESISTANCE
BIN	40°F ± 1°F	25.9kΩ ± 3%	35°F ± 1°F	29.8kΩ ± 3%

EVAPORATOR THERMISTOR

ICE THICKNESS	CUT-IN		CUT-OUT	
	TEMPERATURE	RESISTANCE	TEMPERATURE	RESISTANCE
NORMAL	52.5°F ± 0.3°	18.7kΩ ± 1%	6.5°F ± 0.3°	69.5kΩ ± 1%
THICK	52.5°F ± 0.3°	18.7kΩ ± 1%	4.5°F ± 0.3°	73.9kΩ ± 1%
THIN	52.5°F ± 0.3°	18.7kΩ ± 1%	8.5°F ± 0.3°	65.3kΩ ± 1%

IF EVAPORATOR THERMISTOR IS NOT PRESENT OR OPEN THEN ELECTRONIC CONTROL WILL CONTINUE TO MAKE ICE BASED ON TIME INSTEAD OF TEMPERATURE. (25 MINUTES FOR ICE MAKING AND 4 MINUTES FOR HARVEST)

MINUTES	ON CYCLE						CLEAN CYCLE																			
	POWER ON START UP ONLY		OPERATION				DIAGNOSTICS (SECONDS)						CLEAN CYCLE (MINUTES)													
	2	1	2	ICE MAKING 15min / 25max >6.5°F	HARVEST <52°F	ICE BIN FULL <35°F	*ICE BIN NOT FULL >41°F	3	5	3	5	5	5	5	5	20	3	3	3	3	3	3	3	3	3	
WATER VALVE	On	On	On	On	On	On	On	On	On	On	On	On	On	On	On	On	On	On	On	On	On	On	On	On	On	On
CONDENSOR FAN	On	On	On	On	On	On	On	On	On	On	On	On	On	On	On	On	On	On	On	On	On	On	On	On	On	On
HOT GAS SOLENOID	On	On	On	On	On	On	On	On	On	On	On	On	On	On	On	On	On	On	On	On	On	On	On	On	On	On
RECIRCULATING PUMP	On	On	On	On	On	On	On	On	On	On	On	On	On	On	On	On	On	On	On	On	On	On	On	On	On	On
COMPRESSOR	On	On	On	On	On	On	On	On	On	On	On	On	On	On	On	On	On	On	On	On	On	On	On	On	On	On
LED	On	On	On	On	On	On	On	A	B	C																

- RETURN TO ICE MAKING. PRESS CLEAN SWITCH FOR DIAGNOSTIC MODE.
- TO EXIT CLEAN/DIAGNOSTIC CYCLE PRESS "OFF" TO RESET CONTROL.
- A. FLASHES HERE 2 TIMES IF THERE IS A BIN THERMISTOR FAULT.
- B. FLASHES HERE 5 TIMES IF THERE IS AN EVAPORATOR THERMISTOR FAULT.
- C. LED WILL PAUSE 3 SECONDS HERE.
- IN "HARVEST MODE" THE WATER VALVE WILL SHUT OFF AFTER 1 FULL MINUTE. TOTAL TIME IN HARVEST MODE WILL VARY. THE MINIMUM HARVEST MODE IS 1 MINUTE / MAXIMUM IS 16 MINUTES.
- IN "ICE MAKING MODE" THE FREEZE INTERVAL WILL BE 15 MINUTES MINIMUM TO 25 MINUTES MAXIMUM.

SERVICE AND WIRING SHEET NO.

SERVICE AND WIRING SHEET NO.

2313882 REL

2313882 REL

- NOTE:
- SOLENOID VALVE GROUNDED THROUGH MOUNTING.
 - FUSE IS INTERNAL TO MOTOR.
 - COLOR DESIGNATION IS FOR THE PUSH BUTTON SWITCH NUMBER DESIGNATION IS FOR THE ROCKER SWITCH.

WARNING

Electrical Shock Hazard

Disconnect power before servicing.
Replace all panels before operating.
Failure to do so can result in death or electrical shock.

WIRING DIAGRAM

MANUFACTURED UNDER ONE OR MORE OF THE FOLLOWING UNITED STATES PATENTS

3,960,631 4,659,157 4,765,696 4,908,544 5,011,101
 4,084,725 4,665,708 4,767,896 4,911,508 5,033,182
 4,090,641 4,694,553 4,768,353 4,914,928 5,033,273
 4,102,660 4,706,169 4,776,178 4,920,758 5,042,398
 4,327,557 4,707,401 4,787,216 4,924,680 5,044,704
 4,330,310 4,709,556 4,799,362 4,934,541 5,050,777
 4,640,432 4,715,512 4,800,935 4,936,641 5,070,708
 4,649,712 4,728,759 4,801,181 4,944,566 5,077,985
 4,649,717 4,745,656 4,833,894 4,958,890 D309,461
 4,649,718 4,745,775 4,862,577 4,996,848

OTHER PATENTS PENDING

Printed in U.S.A.

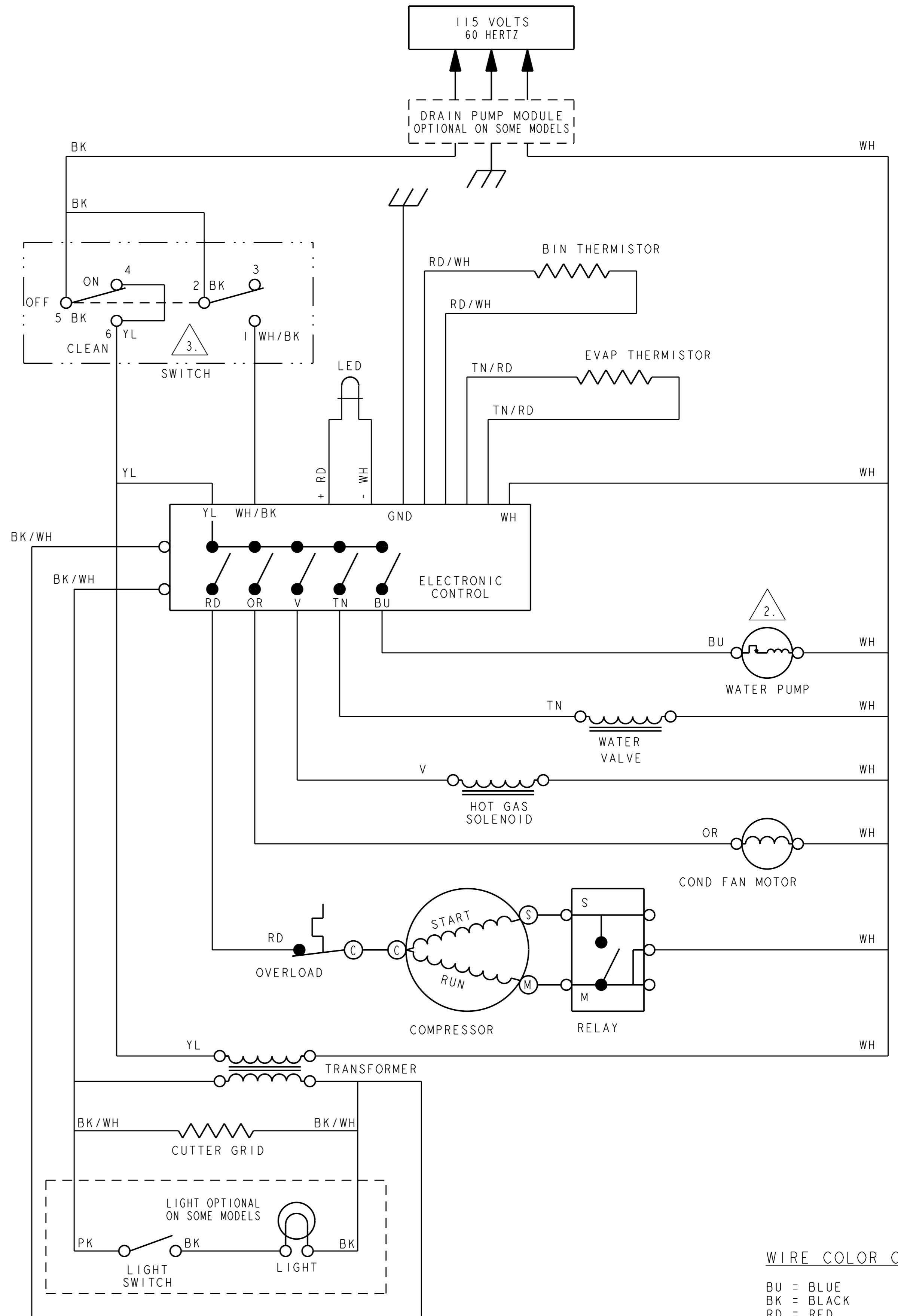
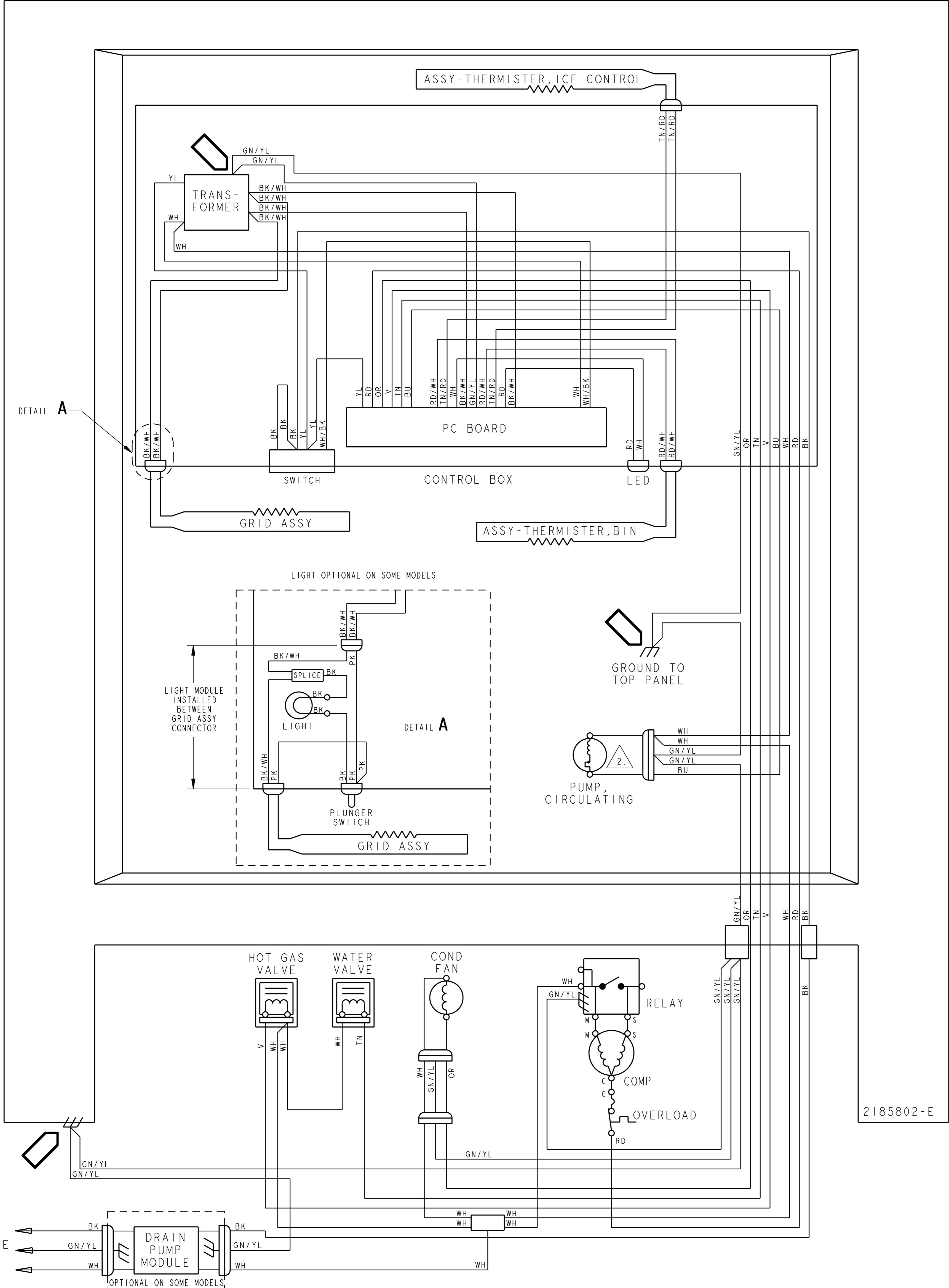

- WIRE COLOR CODE**
- BU = BLUE
 - BK = BLACK
 - RD = RED
 - WH = WHITE
 - YL = YELLOW
 - OR = ORANGE
 - BR = BROWN
 - GY = GRAY
 - PK = PINK
 - V = VIOLET
 - TN = TAN
 - OR/BK = ORANGE/BLACK TRACER
 - YL/RD = YELLOW/RED TRACER
 - BU/BK = BLUE/BLACK TRACER
 - WH/BU = WHITE/BLUE TRACER
 - BK/YL = BLACK/YELLOW TRACER
 - WH/RD = WHITE/RED TRACER
 - GN/YL = GREEN/YELLOW TRACER
 - BK/WH = BLACK/WHITE TRACER
 - YL/BK = YELLOW/BLACK TRACER
 - RD/WH = RED/WHITE TRACER

- SYMBOL CODE**
- ⊙ = CONNECTOR - SCREW ON
 - ⊕ = CONNECTOR - CLOSED END
 - = DISCONNECT TERMINAL
 - = PERMANENT CONNECTION
 - ⇨ = PLUG CONNECTOR
 - ⏏ = GROUND (CHASSIS)

2185802-E